

MASSEY FERGUSON



Disc Mowers, Tedders & Rakes

DM, TD, RK, 1500, 3900, 5000 Series



MASSEY FERGUSON

## Conventional Hay Tools

**FROM MASSEY FERGUSON**  
A world of experience. Working with you.

## CONTENTS

- 3 INTRODUCTION
- 4 FARMER SERIES DISC MOWERS
- 5 PRO SERIES DISC MOWERS
- 6 TD SERIES TEDDERS
- 8 RK SERIES ROTARY RAKES
- 10 1500 SERIES RAKES
- 12 3900 SERIES RAKES
- 13 5130 RAKE
- 14 SERVICE AND SUPPORT
- 16 SPECIFICATIONS





## CHANGING WITH THE TIMES.

Hay and forage products have always been important to Massey Ferguson® and its predecessors. After all, horses and mules were still the source of power back in 1847 when Daniel Massey established our company's roots. And four-footed horsepower needed fuel.

All the while, we've been there with quality hay and forage products and innovative machines — like the 1916 Massey-Harris No. 3 Side Rake and Tedder, designed to save the producer time, storage space and the cost of one machine. No wonder the Massey Ferguson name has thrived for almost 170 years.

We don't have to tell you how hay and forage harvesting has changed in the past few decades, altering both the value and function of rakes and tedders along the way. Today, you need equipment that will help you take control of your harvest — not just rake hay into a windrow.

Yet, every farm is different. So, whether your needs call for a durable and dependable disc mower or an adaptable tedder that can efficiently spread and fluff the crop for faster drydown, a rugged wheel rake that spans 35 feet, or a high-capacity rotary rake for gentler crop handling, there's a Massey Ferguson machine designed specifically for your crop management needs.

Best of all, they're all supported by Massey Ferguson — a world leader in tractors, combines and farm implements for almost 170 years.

# OPTIMIZE YOUR CROP. AND YOUR TIME.



## FARMER SERIES DISC MOWERS

### OUR SPUR GEAR MOWERS LET EVEN SMALLER TRACTORS HANDLE BIG JOBS

Every farmer and rancher has different needs. So no matter the size of your tractor or how tough and uneven your terrain, the economical Massey Ferguson Farmer Series disc mowers will provide smooth cutting, low maintenance and the kind of reliability you demand.

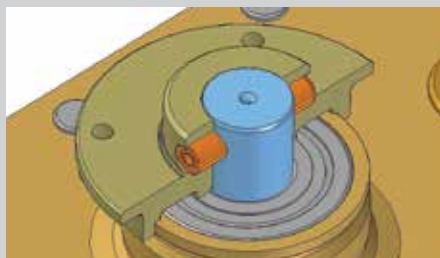

### CONCERNED ABOUT ROCK DAMAGE TO YOUR CUTTERBAR?

No problem. The cutterbar is equipped with a roll/shear pin for every disc that will break outside of the cutterbed, preventing any internal damage and eliminating contamination of the oil bath.

**EXTREMELY FLAT, LOW-PROFILE SPUR GEAR DESIGN** achieves a clean cutting pattern even on difficult terrain. With its sealed common oil bath, you won't waste time checking and refilling each individual module like you do with other disc mowers.



### THE SPRING LOADED ANTI-COLLISION BREAK-AWAY SYSTEM

allows the mower to pivot rearward if the mower comes in contact with an immovable object. This gives the operator time to stop the tractor before serious damage can occur.





## PRO SERIES DISC MOWERS

### THREE MOWERS WITH TECHNOLOGY YOU'LL FIND ONLY FROM MASSEY FERGUSON

Every hay farmer wants the perfect cut. But today, you also need more perfect days, days where you can work faster to achieve the highest capacity, with safeguards that reduce downtime, maintenance and manpower. You'll find them in the three Massey Ferguson Pro Series disc mowers.

#### DRIVEGUARD CUTTERBAR PROTECTION SYSTEM

Our exclusive driveGUARD™ cutterbar protection system prevents damage to the internal cutterbar components. If the mower encounters a rock or foreign object, the shear disc will break, leaving the mowing disc in place, preventing it from flying off when the securing system is released. Shear disc replacement is easy and can be done in minutes, right in the field.

**REMOVABLE TINE CONDITIONER** The removable tine conditioner is unlike any other. Our unique coil design gently conditions and aerates the crop for accelerated drying times. And it takes mere moments to attach or remove. (Optional on DM1358 and DM1361.)

**ROLLER CONDITIONER** Hard stalks are squeezed through the rubber rolls and the delicate, nutrient-rich leaves are preserved. Adjustable contact pressure of the rubber rolls suits various crop conditions, improves crop quality and reduces dry down time. Conditioners are removable. (Optional on DM1358.)

**COMPACT MODULAR ANGLE CUTTERBAR** The low-profile, lightweight and shaft-driven compact modular angle cutterbar boasts a double-bevel gear design. This allows the mower to run at a shallower angle, improving cut quality, optimizing efficiency and extending the life of the cutterbar.

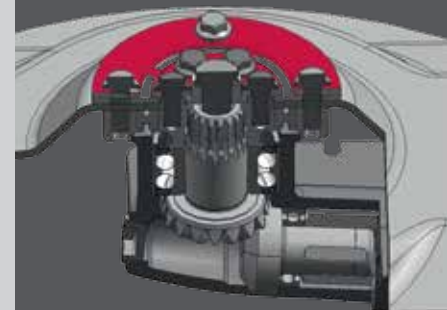

# WHERE MACHINE AND NATURE COME TOGETHER.

## MASSEY FERGUSON TD SERIES TEDDERS

When it comes to drying hay, it's nearly impossible to beat Mother Nature. Of course, farmers have utilized nature's resources, like the wind and sun, for as long as seeds have been planted in the ground. Today, you can accelerate Mother Nature's gifts by spreading the crop with a professional-grade Massey Ferguson TD Series tedder.

Ten models provide tedding widths from 8 feet 2 inches to a full 41 feet 8 inches. Each model offers easily adjusted spreading angles of 15-, 18- and 20.5 degrees adaptability to all forage and crop conditions. The TD Series

even offers a choice of two 25-foot models, including the TD1648, which incorporates its own transport chassis that allows the rotors to fold forward and rest on rubber dampers for high-speed transport between fields.

All models are simple to set-up and adjust for quick and efficient ground coverage. Four, six, eight, and 10-rotor models also feature synchronized lifting of exterior rotors via a centralized hydraulic lift system and pressure cylinders to ensure optimum performance and eliminate one-sided loads — even on slopes.

## COMMERCIAL-GRADE FEATURES

TD Series tedders feature commercial-grade construction that starts with induction-hardened, break-resistant rotor heads for increased durability. The heavy-duty, fully-sealed transmission cases use grease, rather than oil, to ensure quiet operation and longer service intervals. You'll find the same industry-leading philosophy in a myriad of other features that come as standard equipment, including:

- Cutout clutches that protect the U-joints and provide automatic power disconnection when the tedder is raised beyond the headland position while in operation.
- Galvanized tine supports with super "C" spring tines and built-in tine savers ensure durability and reliable performance.
- Close coupling between the rotor support wheels and the tines provide quick response to contours with optimal height adjustment.
- A 1:2 transmission ratio for maximum performance at minimum PTO speeds.





# HIGH-QUALITY SWATHS, EVEN IN HEAVY FORAGE.

## MASSEY FERGUSON RK SERIES ROTARY RAKES

It used to be that if you needed high-capacity and wide raking widths, your only option was a wheel rake. Yet, rotary rakes have deservedly earned their reputation for well-formed, less-roped windrows that allow maximum air circulation and fast crop drying.

Of course, with Massey Ferguson RK Series rotary rakes, you can have your cake and eat it too. Available in eight models with crop gathering widths up to 41 feet, RK Series rotary rakes feature gentle crop handling and the capacity that operators of big balers and self-propelled forage harvesters demand for harvester efficiency.

By gently sweeping the crop, rather than rolling it to the center as a wheel rake does, RK Series rotary rakes maximize leaf retention and crop quality while building fluffier, faster-drying windrows. The sweeping action also reduces the potential for rocks, dirt and debris in the windrow for a cleaner raking job. Twelve cam-action tine arms per rotor and a heavy-duty vinyl curtain provide easy adjustment of raking action and windrow width so you can build a high-quality windrow in every situation. The RK3855, RK3845 and RK3835 models even offer the choice of center- and right-side delivery (two swaths) or right-side only delivery (single swath).





## SUPERIOR SUSPENSION MAKES THE DIFFERENCE

The role of any good rake is to make a clean sweep of the field, no matter how rough or rolling the terrain. Fortunately, RK Series rakes were designed to follow contours better than any other rake on the market.

One secret is our patented ROTORFLEX™ suspension system that allows the staggered rotors on the two- and four-rotor models to move freely over the ground, no matter the contour. While the overhead frame and rear chassis wheels provide support and suspension, each individual rotor rides on its own chassis to independently glide over bumps, hills and hollows without scratching, gouging or jumping over crop material.



**THE ROTORFLEX SUSPENSION** features “jet-effect” lifting and lowering, which means the front lifts first and lowers last, to keep tines from diving into the ground.

A sliding-bearing rear mount with ball-and-socket front mount provide each rotor with unmatched ground-following flexibility.

Even the trailed, single-rotor models feature offset tandem wheels that not only provide flotation, but oscillate over bumps and ditches.

- An adjustable control cam provides optimum formation of swaths for follow-up balers or harvesters — without the use of tools.
- Strong single-stage bevel gears and divided pinion shafts with three bearings each ensure a long service life.



**LONG TINES** feature smooth front surfaces for long life and smooth crop release, creating a clean, uniform windrow.

- The hydraulic lift system means rotors don't need to be switched off at the end of the field for headland turning.
- The heavy-duty frame and steering rear axle, coupled with flexing rotor heads that are part of the RotorFlex system, provide unmatched strength and flexibility.



**A FULLY ENCLOSED GEARBOX** on each rotor prevents contamination from dust, dirt and debris for maximum reliability. The helical-cut gears and sealed cam track are also permanently lubricated with grease, rather than oil, to prevent leakage and increase service life.

# AN AFFORDABLE SOLUTION FOR ANY NEED.



## MASSEY FERGUSON 1500 SERIES VERTICAL FOLD WHEEL RAKES

Today's mower conditioners and self-propelled windrowers that cut, condition and windrow the crop in one operation certainly make life easier under average conditions. But who can count on average?

Available in three sizes, Massey Ferguson 1500 Series vertical fold wheel rakes are ideal for the producer who occasionally needs a rake for pulling two windrows together, turning damp windrows or windrowing hay that has been mowed, tilled or laid down in swaths. Choose between the 8-wheel 1508 model with raking widths up to 20 feet, the 10-wheel 1510 model with a maximum raking width of 22 feet or the 12-wheel 1512 model with raking widths to 24 feet.

Each model features three different raking widths within its range, as well as windrow adjustments that varies from 48 to 72 inches in six-inch increments. One single-acting cylinder folds both wings for easy transport. Additionally, all three models are designed so the left-hand wing can be locked, allowing only the right side of the rake to lower for single-side raking or for turning windrows.





## WHERE TOUGHNESS AND ECONOMY INTERSECT

Although the 1500 Series offers a low-cost alternative to the 3900 Series (see Page 12), they still feature sturdy construction to stand up to the rigors of field contours, while supporting rake wheels at a pre-set level. You also get:

- A rugged box-beam frame that ensures both stability on rough terrain and a long service life.
- The same 55-inch-diameter rake wheels used on the 3900 Series for efficient handling of heavy crop materials and easy replacement.
- Rake wheels mounted in pairs on pivoting brackets that oscillate over field contours and pick material that others miss.
- An adjustable drawbar clevis that allows you to level the rake wheel beams to match the tractor drawbar height.
- Your choice of three raking widths on each model, so you can fine-tune your width by simply adjusting the turnbuckle on each wing.



**ADJUSTABLE FLOAT SPRINGS** on each rake arm let the operator select just the right amount of down pressure for the crop and field conditions.



**ONE SINGLE-ACTING CYLINDER** folds both wings for easy transport.

# HEAVY DEMANDS CALL FOR INCREASED CAPACITY.



## MASSEY FERGUSON 3900 SERIES HIGH-CAPACITY WHEEL RAKES

You get a lot more than a heavy-duty frame and inboard rake wheels on the Massey Ferguson 3900 Series high-capacity rake models. You also gain the benefit of infinitely variable raking widths within the minimum and maximum range, along with a wide choice of windrow widths that are easily adjusted with a single crank arm.

Maximum raking width on the 12-wheel 3983 model is 24 feet, while full raking width on the 14-wheel 3986 model is 28 feet. There's even an optional kit to convert the 3986 model to a 16-wheel rake as your operation grows. Still, both fold to as little as eight feet for transport on country roads and through narrow gates.

Because rake wheels are mounted on the inboard side of the folding frame, there are no restrictions to a continuous flow of high-volume hay. There's nothing to keep the windrow from making a clean exit, either, thanks to the overhead frame at the rear.



**FOLDED FOR TRANSPORT**, the 3986 and 3983 models fold to 8 feet — all without ever leaving the tractor seat.



**AN OPTIONAL CENTER KICKER WHEEL** is available on both 3900 Series wheel rakes, as well as all 1500 Series rakes to turn the entire windrow and eliminate any wet spots beneath unraked crop.



## IT'S YOUR BUSINESS, SO RAKE IT ALL IN

### MASSEY FERGUSON 5130 HEAVY-DUTY WHEEL RAKE

There's a reason we call the Massey Ferguson 5130 a heavy-duty rake. Take one look at the rugged frame and sturdy rake wheels and you'll know this machine was designed for commercial operators who need to satisfy the appetite of big balers and self-propelled forage harvesters. What's more, every function of the 5130 heavy-duty rake is controlled via a bank of electro-hydraulic valves operated by a cab-mounted control box.

Equipped with 17 rake wheels on offset rake beams, the 5130 offers raking widths that are infinitely adjustable from 0 to 30.3 feet. Windrow widths are also infinitely adjustable up to 72 inches.

When it comes time for road transport, the 5130 folds to a width of only 12 feet, 3 inches, making it easier to move from field to field and through narrow gates.

**THE CONTROL BOX** provides the operator with complete control of the rake and windrow, including the ability to individually extend or retract each side of the rake frame and/or tilt the rake beams up to 10 degrees. Rake wings can also be opened or closed individually; the right and left side rake wheels can be raised or lowered individually, or the rake wheels can be raised and lowered together using a single master switch.



If there's any doubt left about the strength and versatility of the Massey Ferguson 5130, check out these features that put it in a class of its own.

- Walking beam rear axles and tandem wheels ensure more stability over rough ground and limited oscillation.
- The large 60-inch diameter rake wheels are each equipped with 36 rubber-mounted rake teeth for a cleaner job of raking.
- Wheel hubs are cast iron for longer life than steel plate. Plus, the wheel hubs, which incorporate an anti-wrap guard, rotate on tapered roller bearing packed in grease.
- Each rake wheel has its own torsional dampening spring, so it floats independently. Plus, the amount of ground pressure on the rake wheels is adjustable.
- Poly wind panels are standard on all rake wheels to help prevent the crop from blowing after the rake wheels lift it off the ground.
- Transport lights and an SMV sign, along with one work light for raking at night, are provided as standard equipment.

# INVEST WISELY.



### **LOW-RATE, FLEXIBLE FINANCING**

Your dealer and AGCO Finance offer attractive financing to make sure your new rake, tedder or disc mower will fit your operating budget. Extremely competitive rates and terms make it easy to buy, lease or rent.

### **AGCO PARTS**

Genuine Massey Ferguson replacement parts are manufactured to the same high standards of quality and dependability as the original part used on the assembly line. Using original equipment parts will help keep your Massey Ferguson equipment running like new.

### **ALL-INCLUSIVE WARRANTY**

Even our warranty is high-performance. The one-year/unlimited hour, all-inclusive warranty on parts and labor is one of the best in the business. More importantly, it's backed by dealers who understand how to help you make the most of it.



*Farm Life* magazine is our exclusive publication that offers farming news, interviews and insights – for and by farmers like you. Visit us online at [myfarmlife.com](http://myfarmlife.com)



### **A GREAT DEAL INCLUDES A GREAT DEALER**

If you're like most farmers, when you find an excellent piece of equipment, it becomes almost like part of your family. And when you buy a Massey Ferguson rake, tedder or disc mower you instantly become part of ours. Our network of dealers knows what it takes to put up quality hay and they have the knowledge to match the right machine with the right producer. They'll advise and support you through the selection process, the buying process, through operation, maintenance and beyond. Because our dealers share your passion for farming, they're happy to share their knowledge to keep you working productively. After all, you're family. And there's nothing we wouldn't do for family.

### **AGCO ANSWERS**

At AGCO, customer care isn't just a department — it's a commitment. Contact us with your questions. We'll do our best to answer them promptly, or put you in touch with someone who can. (877) 525-4384 [agcoanswers@agcocorp.com](mailto:agcoanswers@agcocorp.com)

### **QUESTIONS? GO TO MASSEYFERGUSON.US**

Our website opens the door to all sorts of technical information and product specifications. If you can't find what you're looking for, click on "contact us" and we'll provide you with access to folks who can get you all the answers.

# SPECIFICATIONS\*

## RK SERIES | ROTARY RAKES

MODEL	RK3802	RK3814H	RK3814	RK3835	RK3845	RK3855	RK3879 PRO	RK3891
<b>DIMENSIONS AND WEIGHTS</b>								
Working widths ft. (m)	11'10" (3.6m)	14'9" (4.5)	14'9" (4.5)	20'8" (6.3) / 23 (7)	18'10" (5.75) / 21'10" (6.65)	21'8" (6.6) / 25'3" (7.7)	23'7" (7.2) to 26'3" (8)	41 (12.5)
Windrow widths ft. (m)	2 to 4'11" (.6 to 1.5)	2'6" to 5'3" (.76 to 1.6)	2'6" to 5'3" (.76 to 1.6)	2 to 6'3" (.6 to 1.9)	2 to 6'3" (.6 to 1.9)	2 to 6'3" (.6 to 1.9)	3'11" to 6'7" (1.2 to 2)	3'11" to 7'3" (1.2 to 2.2)
Number of possible windrows	1	1	1	1	2	2	1	1
Length transport ft. (m)	7'3" (2.21)	8'10" (2.68)	8'10" (2.68)	27'9" (8.45)	21'9" (6.65)	24'5" (7.45)	17'7" (5.35)	27'11" (8.5)
Width transport ft. (m)	5'1" (2.1)	6'6" (1.99)	6'6" (1.99)	7'2" (2.3) / 9'10" (3)	9'9" (2.97)	9'10" (3)	9'9" (2.98)	9'10" (3)
Weight lbs. (kg.)	926	1,367 (620)	1,367 (620)	3,042 (1,380)	3,417 (1,550)	4,629 (2,100)	4,519 (2,050)	9,480 (4,300)
Mainframe type	3-point Cat I & II	3-point Cat I & II	Drawbar	Drawbar	3-point Cat I & II	3-point Cat I & II	3-point Cat I & II	3-point Cat I & II
PTO driveline	1 3/8 – 6 spline with torque limiter							
Transport tires	–	–	–	–	2x10 / 75-15.3	2x10 / 75-15.3	2x10 / 75-15.3	2x500 / 50-17
<b>ROTOR</b>								
Number of rotors	1	1	1	2	2	2	2	4
Swath deposit	Right			Right or center & right			Center	
Overall diameter in. (m)	106 (2.7)	134 (3.4)	134 (3.4)	117 (2.96)	108 & 109 (2.74 & 2.78)	126 (3.2)	134 (3.4)	126 (3.2)
Number of tine arms	10	12	12	12 & 12	10 & 12	12 & 12	12 & 12	12/12/12/12
Number of double tines per arm	3	4	4	4	4	4 & 5	4	4
Tandem axle	Standard							
Tires	4x16 / 6.50-8			8x18 / 8.50-8	8x16 / 6.50-8	8x16 / 6.50-8	8x18 / 8.50-8	16x16 / 6.50-8
<b>TRACTOR REQUIREMENTS</b>								
Minimum Engine Horsepower (kW)	27 (20)	41 (30)	41 (30)	45 (33)	26 (19)	41 (30)	48 (35)	80 (59)
PTO speed RPM	540 RPM							
Hydraulics	–	–	1 SAV	1 SAV, 1 DAV	1 SAV	1 SAV	1 SAV	2 SAV (1 with float)
Standard Equipment	Parking stand, transport safety chain and SMV emblem							





## TD SERIES | TEDDERS

MODELS	TD1620	TD1635	TD1635H	TD1636	TD1638	TD1648	TD1655	TD1661	TD1663	TD1665
<b>DIMENSIONS AND WEIGHTS</b>										
Working width ft. (m)	8'2" (2.5)	17'1" (5.2)	17'1" (5.2)	21'8" (6.6)	25'3" (7.7)	25'3" (7.7)	33'6" (10.2)	33'6" (10.2)	41'8" (12.7)	41'8" (12.7)
Transport width ft. (m)	9'10" (3.0)	9'10" (3)	9'10" (3)	9'6" (2.9)	9'10" (3)	9'10" (3)	9'8" (2.94)	9'2" (2.78)	9'2" (2.78)	9'8" (2.94)
Length ft. (m)	10'2" (3.1)	10'2" (3.1)	7'5" (2.25)	6'11" (2.1)	8 (2.45)	14'8" (4.5)	18'8" (5.7)	22'5" (6.83)	26'6" (8)	18'8" (5.7)
Weight lbs. (kg.)	513 (233)	1,224 (555)	1,336 (606)	1,812 (822)	2,086 (946)	2,727 (1,237)	4,162 (1,888)	2,403 (1,090)	2,877 (1,305)	4,718 (2,140)
<b>MAINFRAME</b>										
Transport	–	Hydraulic vertical fold				Transport chassis		Hydraulic horizontal rear fold		Transport Chassis
Rotors	2	4	4	6	6	6	8	8	10	10
Double tines per rotor	6									
Wheels	2	4	4	6	6	6	8	8	8	10
Rotor tire size	16-6:50 x 8									
<b>GENERAL</b>										
Tractor attachment	Drawbar		3 pt-Cat 1 & II				Drawbar			
Minimum Engine Horsepower (kW)	20 (15)	30 (22)	30 (22)	41 (30)	82 (60)	41 (31)	54 (40)	48 (35)	61 (45)	90 (66)
PTO speed RPM	540 RPM									
Hydraulics	–	1 SAV	1 SAV	1 SAV	1 SAV	1 SAV + 1 DAV	1 SAV + 1 DAV	1 SAV	1 SAV	1 SAV

## 1500 SERIES | VERTICAL FOLD WHEEL RAKES

MODEL	1508	1510	1512	MODEL	1508	1510	1512
<b>DIMENSIONS AND WEIGHTS</b>							
Transport width ft. (m)	9'6" (2.9)	9'6" (2.9)	10'6" (3.2)	<b>FINGER WHEELS</b>	8	10	12
Overall length ft. (m)	12'8" (3.9)	15'6" (4.8)	18 (5.5)		Overall diameter in. (mm)	55 (1,397)	
Weight lbs. (kg.)	1,125 (510)	1,275 (578)	1,440 (653)		Tines per wheel	40	
Raking widths ft. (m)	3 positions from 16 to 20 (4.1 to 6.1)	3 positions from 18 to 22 (5.5 to 6.7)	3 positions from 20 to 24 (6.1 to 7.3)		Tine diameter in. (mm)	0.3 (7)	
Windrow widths in. (mm)	Variable from 48 to 72 (1,219 to 1,829)				Rake wheel bearings	Tapered roller bearings with dust covers	
Raking positions	3				Flotation	Dual-wheel flotation	
Frame fold	Hydraulic				Lift	Single cylinder – both sides	
Tire size	ST175/80D13				<b>TRACTOR REQUIREMENTS</b>		
Gauge wheels in. (mm)	12 (305)	15 (381)	6:70 x 15	Minimum Engine Horsepower (kW)	25 (19)	25 (19)	30 (22)
				Hydraulics	1 SAV		
				<b>OPTIONAL KITS</b>			

\*Specifications are manufacturer's estimates at time of publication and are subject to change without prior notification.

# SPECIFICATIONS\*



## 3900 SERIES | HIGH CAPACITY WHEEL RAKES

MODEL	3983	3986
<b>DIMENSIONS AND WEIGHTS</b>		
Transport width ft. (m)	8 (2.4)	8'1" (2.5)
Overall length ft. (m)	24'6" (7.5)	27'3" (8.4)
Weight lbs. (kg.)	3,500 (1,587)	3,800 (1,723)
Raking widths ft. (m)	0 to 24 (0 to 7.3)	0 to 28 (0 to 8.5)
Windrow widths in. (mm)	Variable from 38 to 58 (965 to 1,473)	
<b>MAINFRAME</b>		
Raking positions	Infinitely variable	
Frame fold	Hydraulic	
Tire sizes in. (mm)	P205-75 x 15	
Gauge wheels in. (mm)	12 (305)	15 (381)

MODEL	3983	3986
<b>FINGER WHEELS</b>		
Number	12	14
Overall diameter in. (mm)	55 (1,397)	
Tines per wheel in. (mm)	40	
Tine diameter	0.3 (7)	
Rake wheel bearings	Tapered roller	
Flotation	Wheels pivot independently	
Lift	Single-acting cylinder per side	
<b>TRACTOR REQUIREMENTS</b>		
Minimum Engine Horsepower (kW)	30 (22)	40 (30)
Hydraulics	1 SAV + 1 DAV	



## 5000 SERIES | HEAVY-DUTY WHEEL RAKES

MODEL	5130
<b>DIMENSIONS AND WEIGHTS</b>	
Transport width ft. (m)	12'3" (3.7)
Overall length ft. (m)	28'3" (8.6)
Weight lbs. (kg.)	5,800 (2,631)
Raking widths ft. (m)	Up to 30'3" (9.2)
Windrow widths in. (mm)	Up to 72 (1.8)
<b>MAINFRAME</b>	
Raking positions	Infinitely variable
Frame fold	Hydraulic
Tire sizes in. (mm)	9.5L x 15
Gauge wheels in. (mm)	NA

MODEL	5130
<b>FINGER WHEELS</b>	
Number	17
Overall diameter in. (mm)	60 (1,524)
Tines per wheel in. (mm)	36
Tine diameter	NA
Rake wheel bearings	Tapered roller
Flotation	One spring per wheel
Lift	Double-acting lift cylinder per side
<b>TRACTOR REQUIREMENTS</b>	
Minimum Engine Horsepower (kW)	65 (48.5)
Hydraulics	1 SAV + 1 DAV

\*Specifications are manufacturer's estimates at time of publication and are subject to change without prior notification.

## FARMER SERIES | DISC MOWERS

MODEL	DM1305	DM1306	DM1308	DM1309
Working width ft. (m)	5' 5" (1.66)	6' 9" (2.06)	7' 11" (2.42)	9' 3" (2.82)
Swath width ft. (m)	2' 11" (0.9)	4' 1" (1.25)	5' 5" (1.65)	6' 7" (2)
Transport height ft. (m)	8' 2" (2.5)	9' 4" (2.9)	10' 7" (3.25)	11' 10" (3.6)
Cutterbar type	Spur gear			
Disc	4	5	6	7
Blades per disc	2			
Disc speed	3,000 RPM			
Tip speed	179 mph			
Power requirement	30 HP	41 HP	50 HP	60 HP
Hydraulic requirement	1 SAV			
PTO speed	540 RPM			
Overrunning clutch	Standard			
Weight lbs.	820	897	963	1,047



## PRO SERIES | DISC MOWERS

MODEL	DM1358	DM1358 with Tine Conditioner	DM1358 with Roller Conditioner	DM1361	DM1361 with Tine Conditioner	DM1362
Working width ft. (m)	8' 4" (2.55)	8' 4" (2.55)	8' 4" (2.55)	9' 10" (3)	9' 10" (3)	11' 6" (3.5)
Swath width ft. (m)	5' 3" (1.6)	2' 11" to 4' 7" (0.9 to 1.4)	3' 5" to 4' 7" (1.05 to 1.4)	5' 11" (1.8)	2' 11" to 6' 3" (1.35 to 1.9)	7' 6" (2.3)
Transport height ft. (m)	9' 8" (3)	9' 8" (3)	9' 8" (3)	11' 3" (3.5)	11' 3" (3.5)	12' 10" (4)
Cutterbar type	Compact modular angular gear (shaft drive)					
Disc	5	5	5	6	6	7
Blades per disc	2					
Disc speed	3,000 RPM					
Tip speed mph	179					
Cutterbar protection	Drive guard & rupture joint					
Power requirement	54 HP	75 HP	75 HP	61 HP	86 HP	68 HP
Hydraulic requirement	1 SAV					
PTO speed	540 RPM					
Overrunning clutch	Standard					
Weight lbs.	1,455	1,947	2,161	1,596	2,229	1,760
Coil tine conditioner	Optional	Standard	Optional	Optional	Standard	NA
Roller conditioner	Optional	Optional	Standard	NA	NA	NA





MASSEY FERGUSON

masseyferguson.us



Massey Ferguson DM, TD, RK, 1500, 3900, 5000 Series | Disc Mowers, Tedders & Rakes



We proudly support:

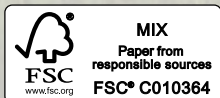

©2015 AGCO® Corporation. Massey Ferguson is a worldwide brand of AGCO Corporation. AGCO, Massey Ferguson, driveGUARD™ and ROTORFLEX™ are trademarks of AGCO. All rights reserved. MF15B010CR (12) 1 PD

AGCO may at any time, and from time to time, for technical or other necessary reasons, modify any of the data, specifications or warranty of the products described herein. Some equipment shown may be optional. Attention: Photographs in this publication may show protective shields and guards open or removed for the purposes of illustration. Be certain all shields and guards are in place during operation.

AGCO is a premier manufacturer of agricultural equipment, providing high-tech solutions for professional farmers feeding the world. The company is dedicated to delivering superior customer service, innovation and quality. AGCO products are distributed in more than 140 countries worldwide.